



BELGARD
PAVES THE WAY™

ARTFORMS™

MODULAR PANEL SYSTEM



IDEA BOOK

BENCH & PLANTER



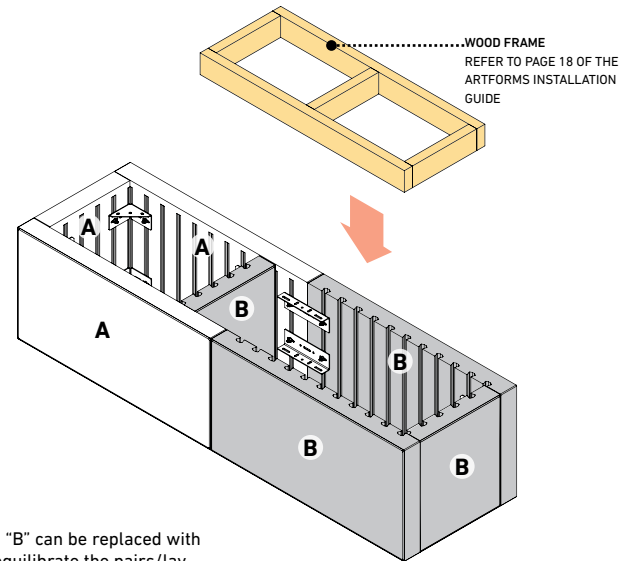

INTERIOR VIEW

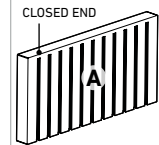
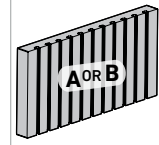
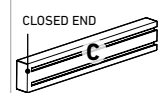

NOTE: Panels "B" can be replaced with panels "A" to equilibrate the pairs/layers. Panels "A" can't be replaced by the panels "B".

REQUIRED PANELS

	18 x 36 PANEL	3x
	18 x 36 PANEL	3x
	6 x 36 PANEL	0x
	6 x 36 PANEL	0x

IMPORTANT: 18 x 36 panels are sold in pair/layer or in full pallet only. 6 x 36 panels are sold per unit or in layer or in full pallet.



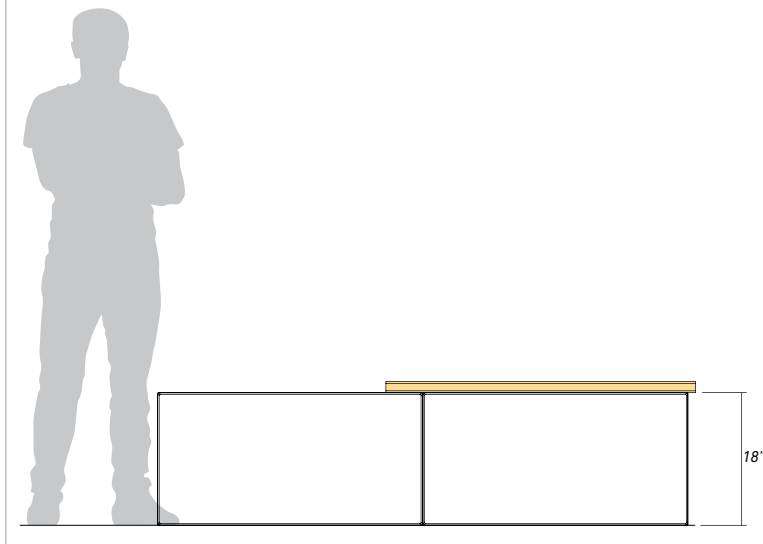

FRONT VIEW

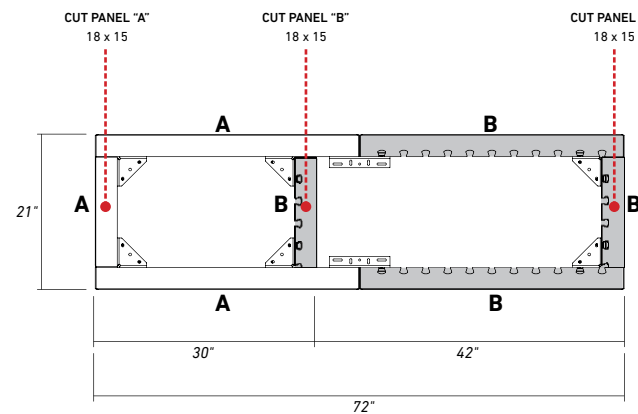

TOP VIEW

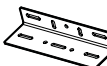

REQUIRED HARDWARE

	ANCHOR SLIDE AND NUT	32x
	JOINING PLATE	4x
	OUTER CORNER	12x
	INNER CORNER	0x
	STRETCHER	0x

IMPORTANT: Refer to page 23 of the ARTFORMS INSTALLATION GUIDE about the installation of geotextile in planter box. Contact experts/engineers to validate the base preparation, the drainage, the plants & roots growth/management.

BENCH & VERTICAL PLANTER



INTERIOR VIEW

WOOD FRAME
REFER TO PAGE 18 OF THE
ARTFORMS INSTALLATION
GUIDE

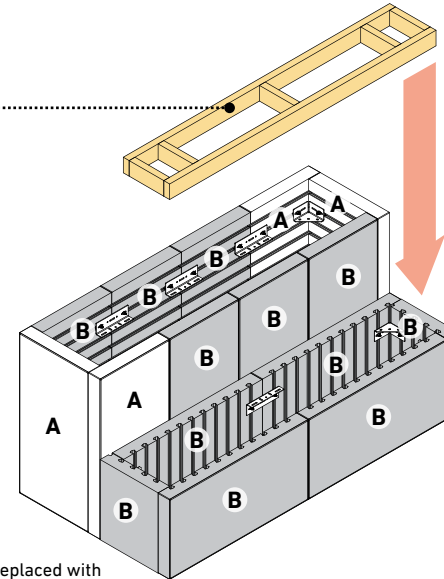

NOTE: Panels "B" can be replaced with panels "A" to equilibrate the pairs/layers. Panels "A" can't be replaced by the panels "B".

REQUIRED PANELS

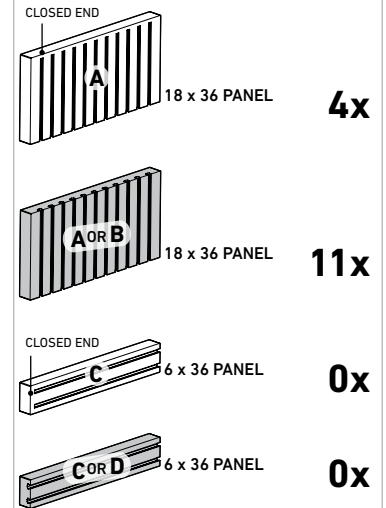

IMPORTANT: 18 x 36 panels are sold in pair/layer or in full pallet only. 6 x 36 panels are sold per unit or in layer or in full pallet.

FRONT VIEW

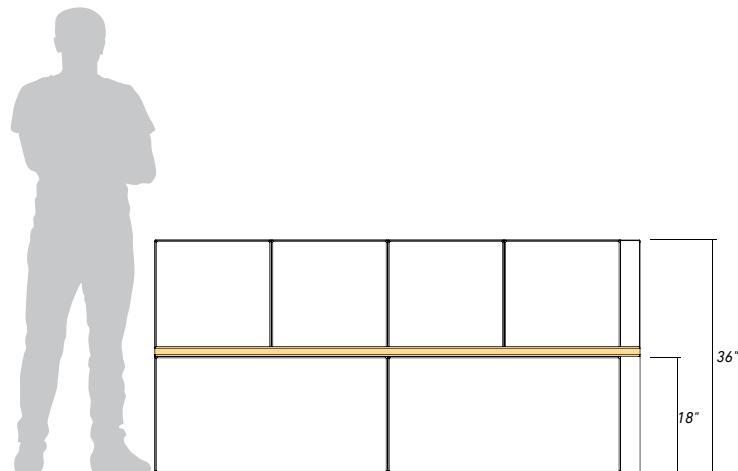

TOP VIEW

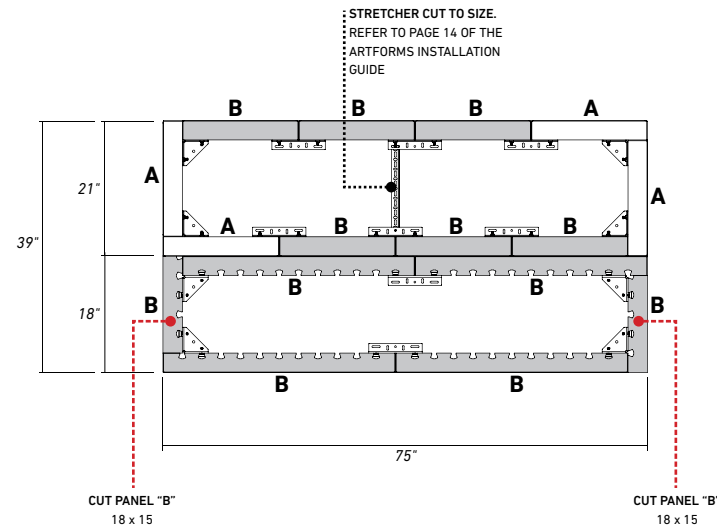

REQUIRED HARDWARE

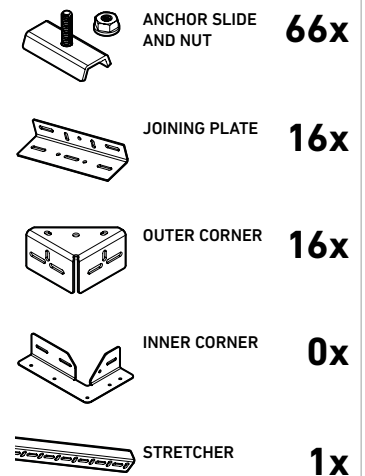

IMPORTANT: Refer to page 23 of the ARTFORMS INSTALLATION GUIDE about the installation of geotextile in planter box. Contact experts/engineers to validate the base preparation, the drainage, the plants & roots growth/management.

SMALL BBQ



INTERIOR VIEW

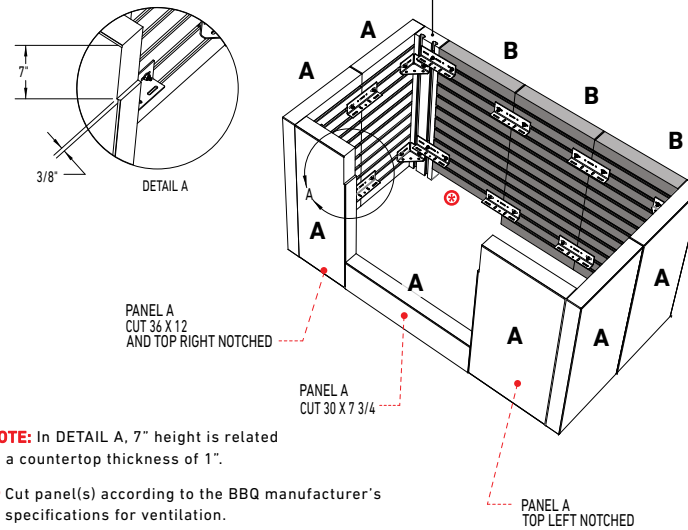

REQUIRED PANELS

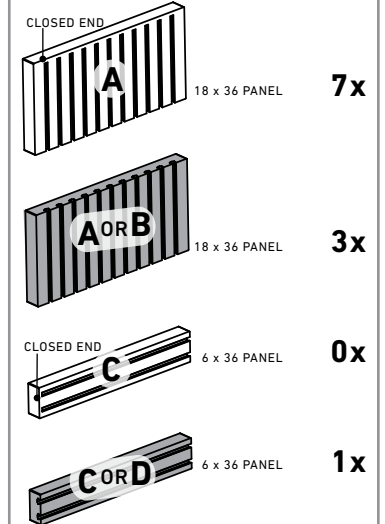

IMPORTANT: 18 x 36 panels are sold in pair/layer or in full pallet only. 6 x 36 panels are sold per unit or in layer or in full pallet.

FRONT VIEW

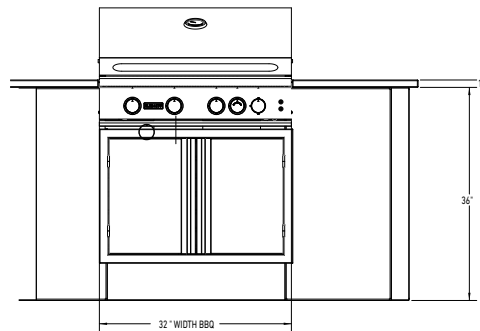

TOP VIEW

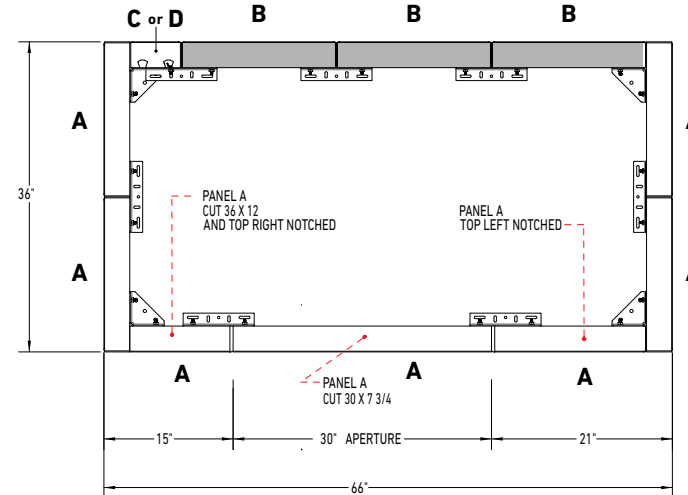

REQUIRED HARDWARE

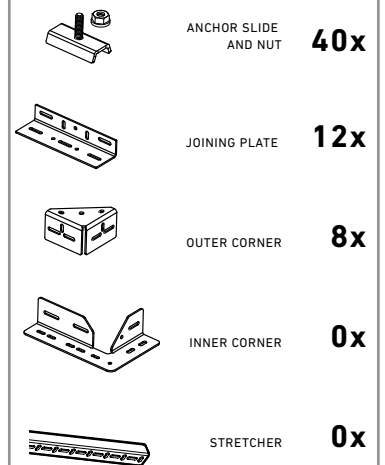

IMPORTANT: It is recommended to follow the BBQ manufacturer's specifications for ventilation and clearances. Belgard is not responsible for the conformity of connections, clearances and ventilation. BBQ, countertop and accessories are not included.

LONG BBQ



INTERIOR VIEW

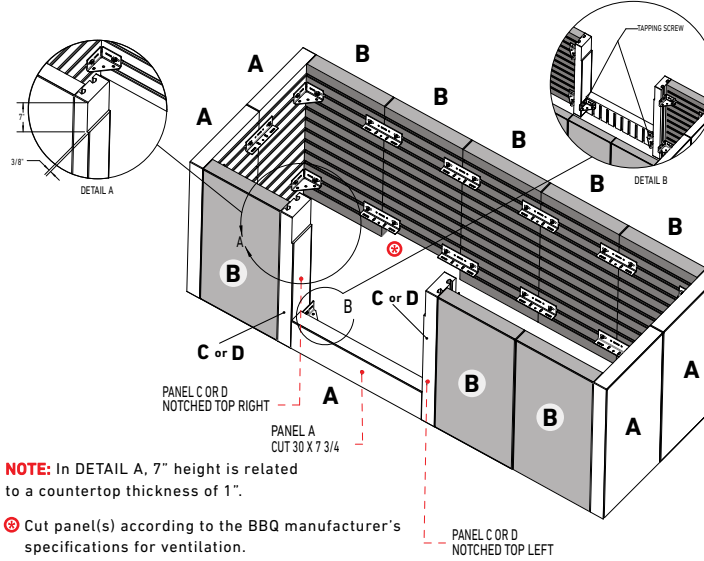

REQUIRED PANELS

	5x
	8x
	2x
	0x

IMPORTANT: 18 x 36 panels are sold in pair/layer or in full pallet only. 6 x 36 panels are sold per unit or in layer or in full pallet.

FRONT VIEW

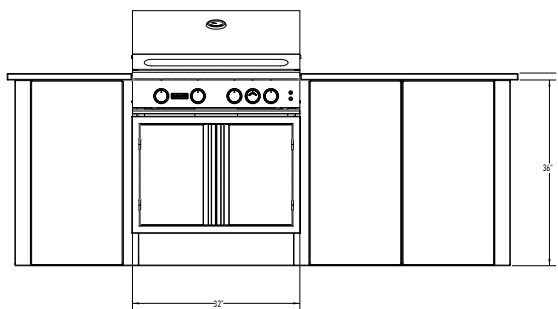

TOP VIEW

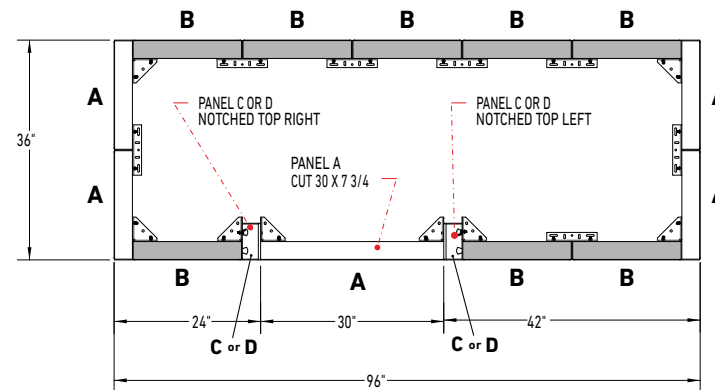

REQUIRED HARDWARE

	56x
	14x
	14x
	0x
	0x

IMPORTANT: It is recommended to follow the BBQ manufacturer's specifications for ventilation and clearances. Belgard is not responsible for the conformity of connections, clearances and ventilation. BBQ, countertop and accessories are not included.

RECESSED GAS FIRE PIT



INTERIOR VIEW

The 30 x 30 burner pan is sitting directly on the ARTFORMS hardware, on the corner's brackets.

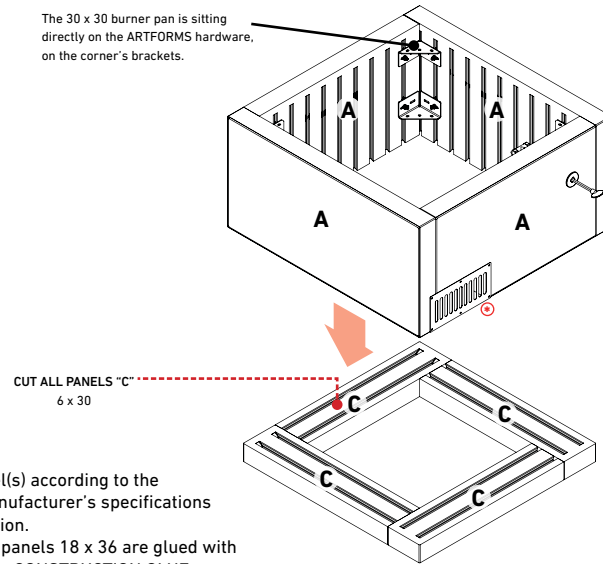

Ⓢ Cut panel(s) according to the burner manufacturer's specifications for ventilation.

NOTE: The panels 18 x 36 are glued with 6 x 36 using CONSTRUCTION GLUE or STRUCTURE BOND

REQUIRED PANELS

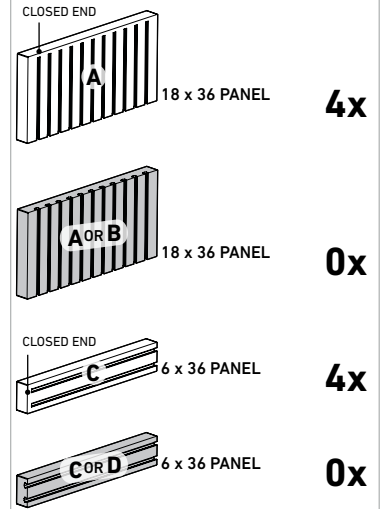

IMPORTANT: 18 x 36 panels are sold in pair/layer or in full pallet only. 6 x 36 panels are sold per unit or in layer or in full pallet.

FRONT VIEW

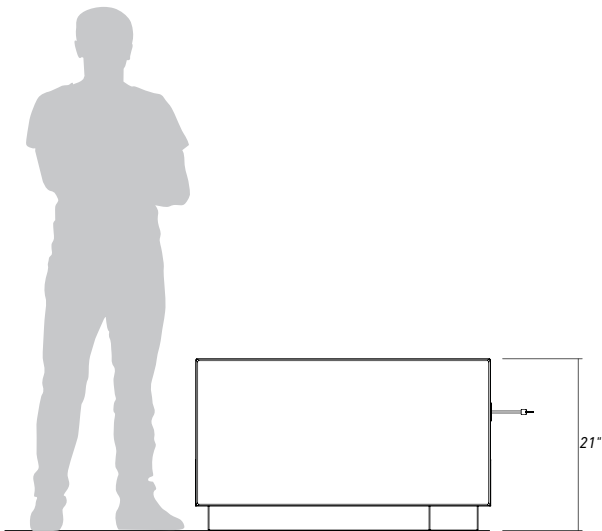

TOP VIEW

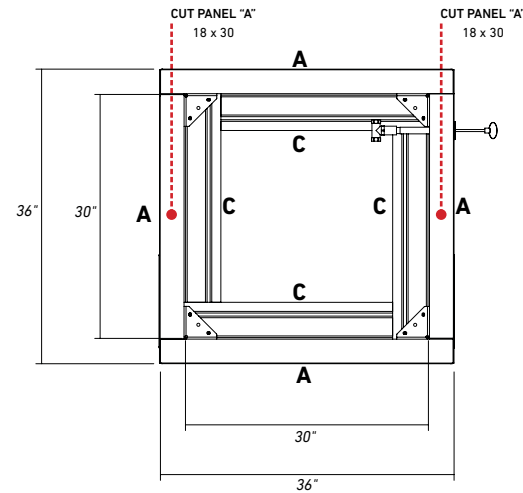

REQUIRED HARDWARE

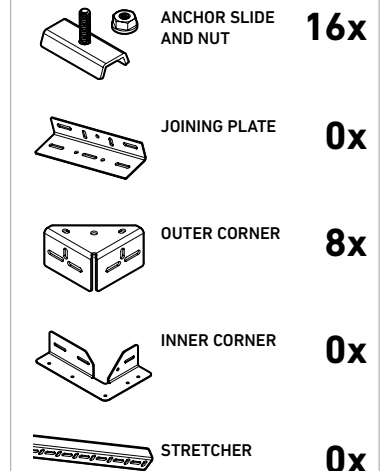

IMPORTANT: It is recommended to follow the burner manufacturer's specifications for ventilation. Belgard is not responsible for the conformity of connections, clearances and ventilation. Burner pan and accessories are not included.

GAS FIRE PIT



INTERIOR VIEW

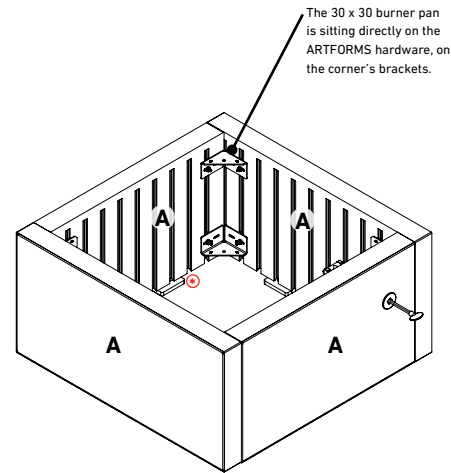

Ⓢ Add 0.5" thick PLASTIC SHIMS for ventilation

REQUIRED PANELS

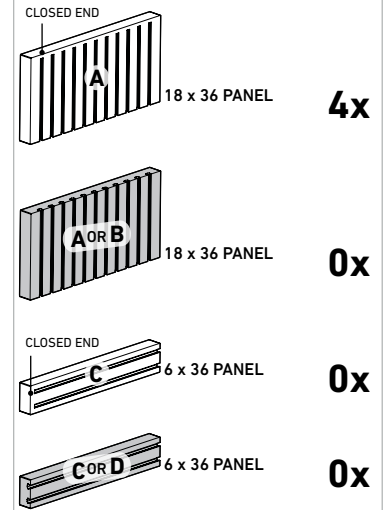

IMPORTANT: 18 x 36 panels are sold in pair/layer or in full pallet only. 6 x 36 panels are sold per unit or in layer or in full pallet.

FRONT VIEW

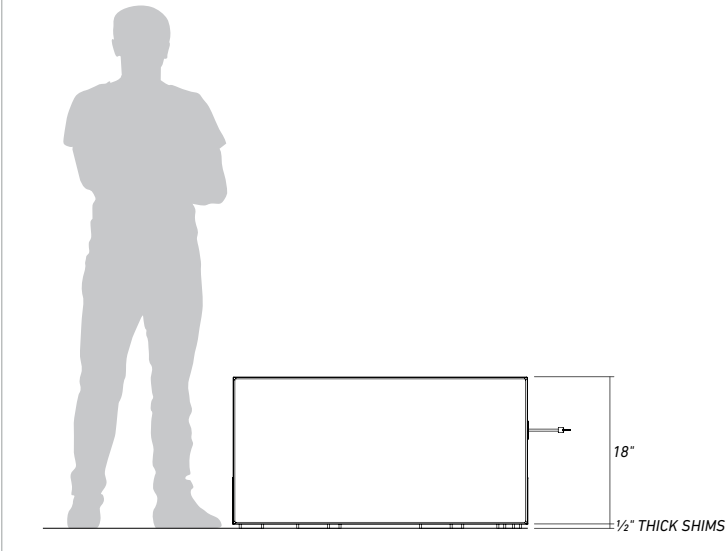

TOP VIEW

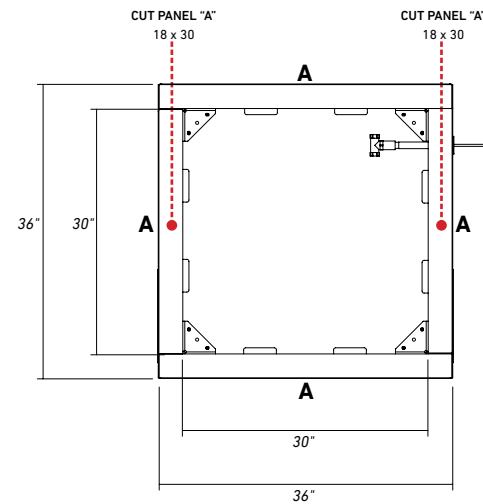

REQUIRED HARDWARE

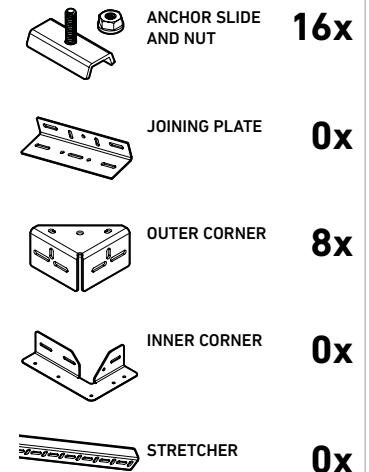

IMPORTANT: It is recommended to follow the firekit manufacturer's specifications for ventilation. Belgard is not responsible for the conformity of connections, clearances and ventilation. Burner pan and accessories are not included.

SQUARE PLANTER





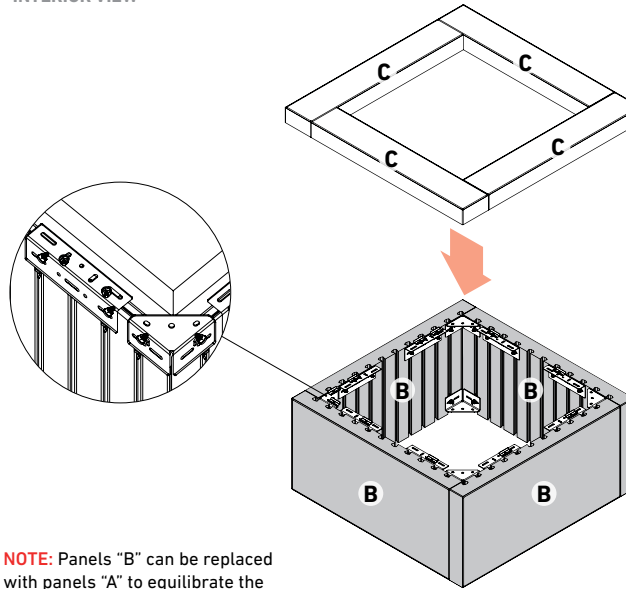

INTERIOR VIEW

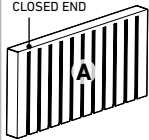

NOTE: Panels "B" can be replaced with panels "A" to equilibrate the pairs/layers. Panels "A" can't be replaced by the panels "B".

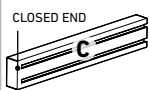
REQUIRED PANELS

	18 x 36 PANEL	0x
	18 x 36 PANEL	4x
	6 x 36 PANEL	4x
	6 x 36 PANEL	0x

IMPORTANT: 18 x 36 panels are sold in pair/layer or in full pallet only. 6 x 36 panels are sold per unit or in layer or in full pallet.

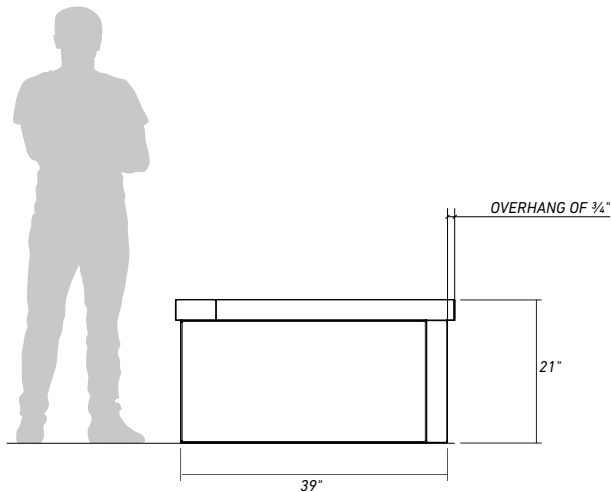

FRONT VIEW

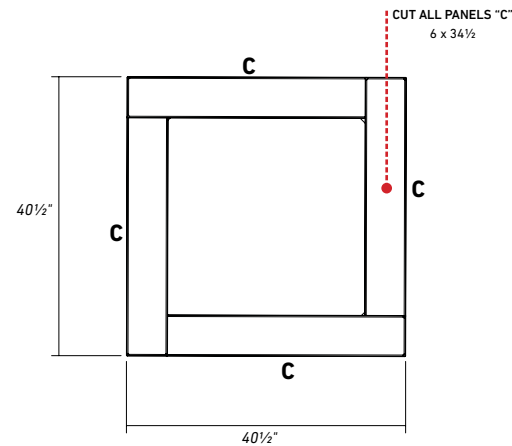

TOP VIEW

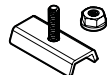
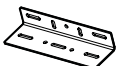
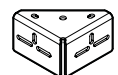

REQUIRED HARDWARE

	ANCHOR SLIDE AND NUT	40x
	JOINING PLATE	8x
	OUTER CORNER	8x
	INNER CORNER	0x
	STRETCHER	0x

IMPORTANT: Refer to page 23 of the ARTFORMS INSTALLATION GUIDE about the installation of geotextile in planter box. Contact experts/engineers to validate the base preparation, the drainage, the plants & roots growth/management.

RECTANGULAR PLANTER



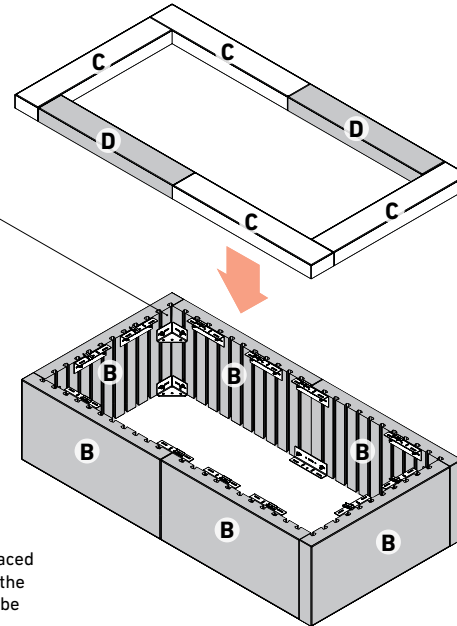
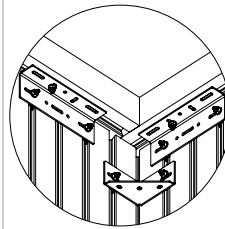

INTERIOR VIEW

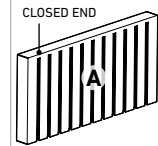
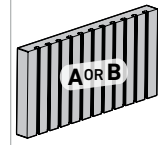
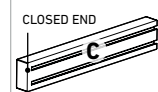

NOTE: Panels "B" can be replaced with panels "A" to equilibrate the pairs/layers. Panels "A" can't be replaced by the panels "B".

REQUIRED PANELS

	18 x 36 PANEL	0x
	18 x 36 PANEL	6x
	6 x 36 PANEL	4x
	6 x 36 PANEL	2x

IMPORTANT: 18 x 36 panels are sold in pair/layer or in full pallet only. 6 x 36 panels are sold per unit or in layer or in full pallet.



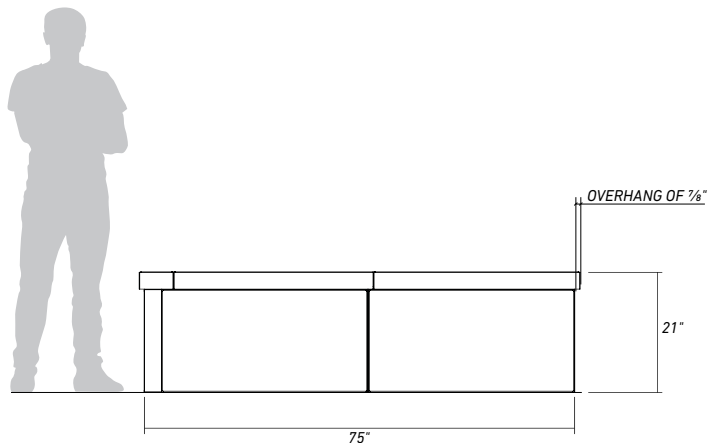

FRONT VIEW

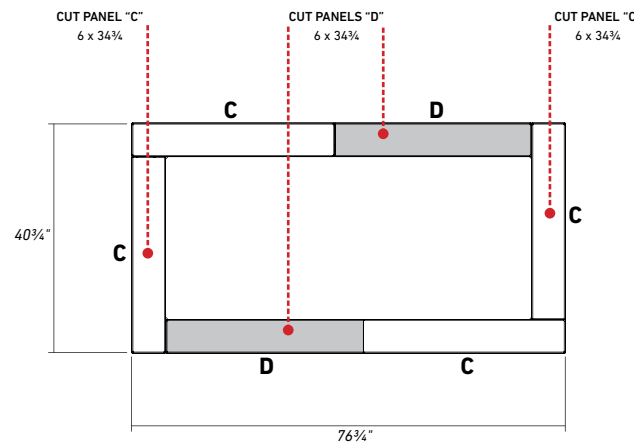

TOP VIEW

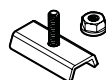
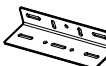

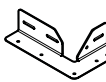
REQUIRED HARDWARE

	ANCHOR SLIDE AND NUT	56x
	JOINING PLATE	14x
	OUTER CORNER	8x
	INNER CORNER	0x
	STRETCHER	0x

IMPORTANT: Refer to page 23 of the ARTFORMS INSTALLATION GUIDE about the installation of geotextile in planter box. Contact experts/engineers to validate the base preparation, the drainage, the plants & roots growth/management.

