

COMMERCIAL

PRODUCT OFFERING

ROOFTOP AND PLAZA SOLUTIONS



BELGARD
COMMERCIAL



AT BELGARD COMMERCIAL,

our mission is to exceed the demands of our customers in the ever-changing hardscapes industry. Owned by the largest manufacturer of concrete materials in North America, Oldcastle APG, we are fortunate to have resources that allow us to adhere to a level of service, quality and consistency that no other supplier can match.

To remain a leader in our industry, our team spends more than 20,000 hours on research and development every year to stay on the cutting edge of design trends, manufacturing techniques and technologies.

Not only are our hardscape products the most trusted industry, they are backed by a team of experts who offer free guidance and consultation. We know that choosing the right products is only half of the job, which is why we're here to help you with everything else. Design, site planning, engineering and whatever it takes to help you succeed.

ATTRACTIVE PLAZA AREAS

offer pedestrians an outdoor place to gather and enjoy fresh air, bright sunshine or beautiful views. Plaza decks on rooftops and terraces provide practical solutions for optimizing space and building decks over sloping, difficult or uneven surfaces. Whether the style is traditional or contemporary, Belgard Commercial's expertise encompasses numerous applications including Schools and Universities, Retail and Office Buildings, Hotels and Restaurants, Government Centers, and Multi-Family or Custom homes.

BELGARDCOMMERCIAL.COM

Table of Contents

PRODUCTS	4
COLORS & FINISHES	12
PRODUCT DETAILS	14
ACCESSORIES	18
INSTALLATION INSTRUCTIONS	22
ROOFTOP PAVER LAYOUT SERVICE	23
REFERENCE INFORMATION	27



Products

CLASSIC PLAZA SLAB CONCRETE SLABS

Classic Plaza Slabs are a high-density concrete suited for use as a plaza deck component providing a durable, yet elegant, roof surface. Plaza slabs are elevated on high density polypropylene pedestals, which provide uniform spacing and draining and can achieve a dead level installation if desired.

DIMENSIONS:

24" x 24" x 1 7/8" nominal

WEIGHT:

23 lbs. per square foot

DIMENSIONAL TOLERANCE:

+/- 1/8" (length, width, height, convex, concave)

WATER ABSORPTION:

less than 5%

POINT LOAD:

2,000 lbs.

FREEZE THAW:

less than 1% loss in weight after 40 cycles

Do not use de-icing agents including but not limited to Ammonium Nitrate, Ammonium Sulfate, Sodium Chloride (Salt) and Calcium Chloride; these agents are destructive to concrete pavers.

During the course of the work and on completion, remove any cutting dust from the surface of the pavers by means of water or air. If left unattended, cut dust can and will discolor pavers. When cleaning with high pressure water, use caution to avoid damage to slabs.

Refer to the Plaza Paver Specifications for more information, which is available for download on BelgardCommercial.com.

WESTERN PLAZA CONCRETE SLABS

- Hydraulically pressed resulting in high density and Point Load for ultimate durability
- Contemporary shot blast matte finish
- Ideal for pedestal set applications
- Provide a durable pedestrian surface
- Large size ideal for plazas and rooftop systems

DIMENSIONS:

24" x 24" x 1 13/16" nominal

12" x 24" x 1 13/16" special order

18" x 18" x 1 13/16" special order

16" x 16" x 1 13/16" special order

WEIGHT:

23 lbs. per square foot

DIMENSIONAL TOLERANCE:

+/- 1/8" (length, width, height, convex, concave)

WATER ABSORPTION:

less than 5% per ASTM C140

POINT LOAD:

2,000 lbs.

FREEZE THAW:

less than 1% loss in weight after 40 cycles per ASTM C67

Do not use de-icing agents including but not limited to Ammonium Nitrate, Ammonium Sulfate, Sodium Chloride (Salt) and Calcium Chloride; these agents are destructive to concrete pavers.

During the course of the work and on completion, remove any cutting dust from the surface of the pavers by means of water or air. If left unattended, cut dust can and will discolor pavers. When cleaning with high pressure water, use caution to avoid damage to slabs.

Refer to the Plaza Paver Specifications for more information, which is available for download on BelgardCommercial.com.

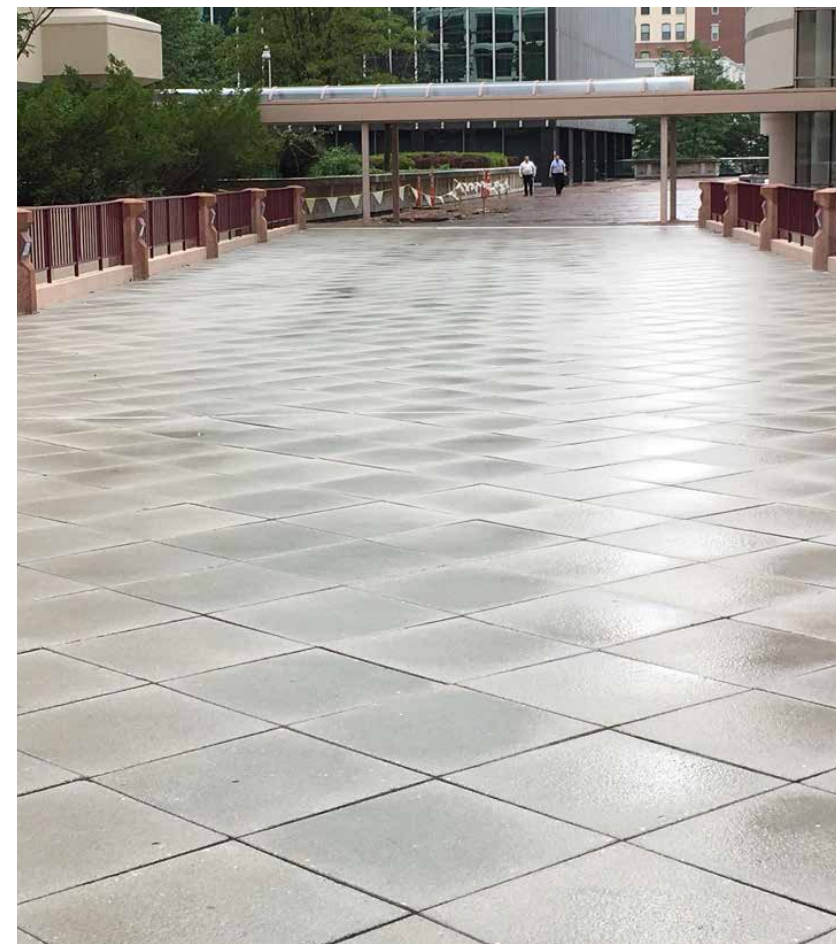
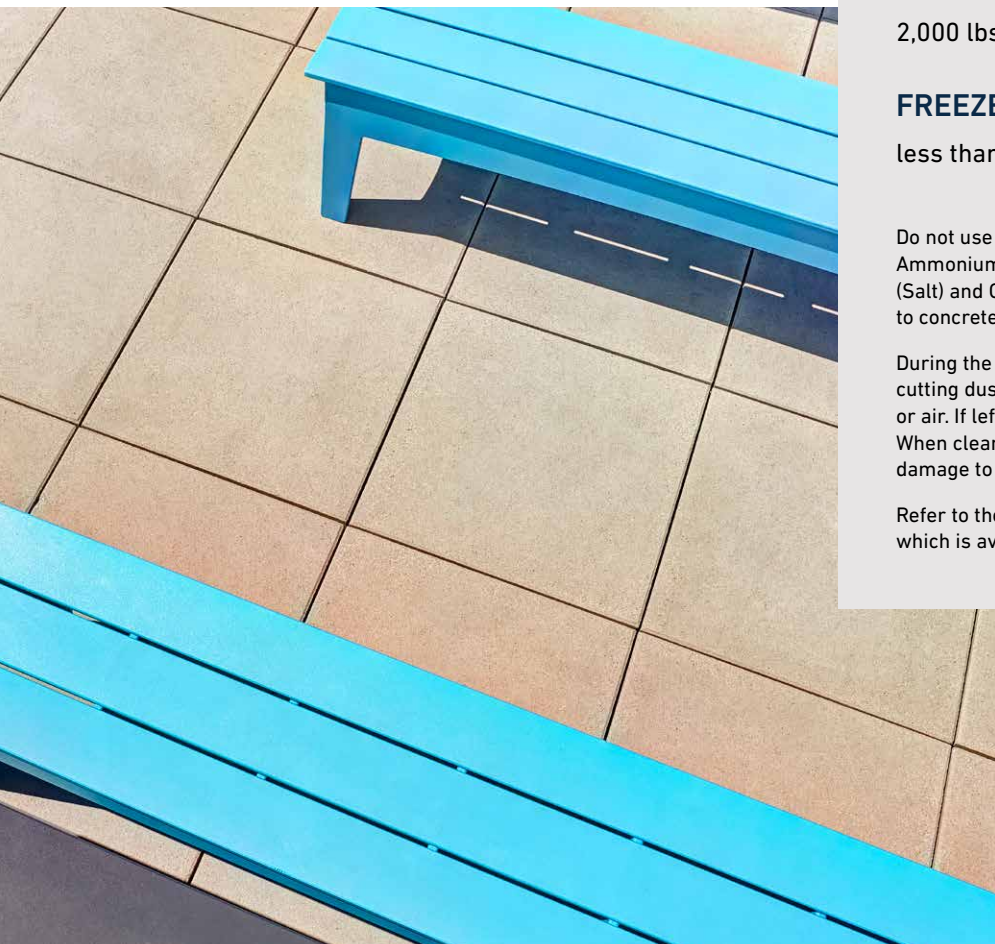

PEDSLAB®

The PedSlab built-in pedestal system is designed to reduce installation labor. The corner pieces allow traditional methods of shimming or leveling, and pedestal edges are relieved to reduce the chance of membrane damage. The 9-pedestal layout gives the PedSlab Pedestal System its unique system.

DIMENSIONS:

24" x 24" x 2.25" nominal
Pedestal height: 3/8" with 50 3/16" of bearing area

WEIGHT:

115 lbs. per slab

WATER ABSORPTION:

less than 5%

POINT LOAD:

2,000 lbs.

FREEZE THAW:

less than 1% loss in weight after 40 cycles

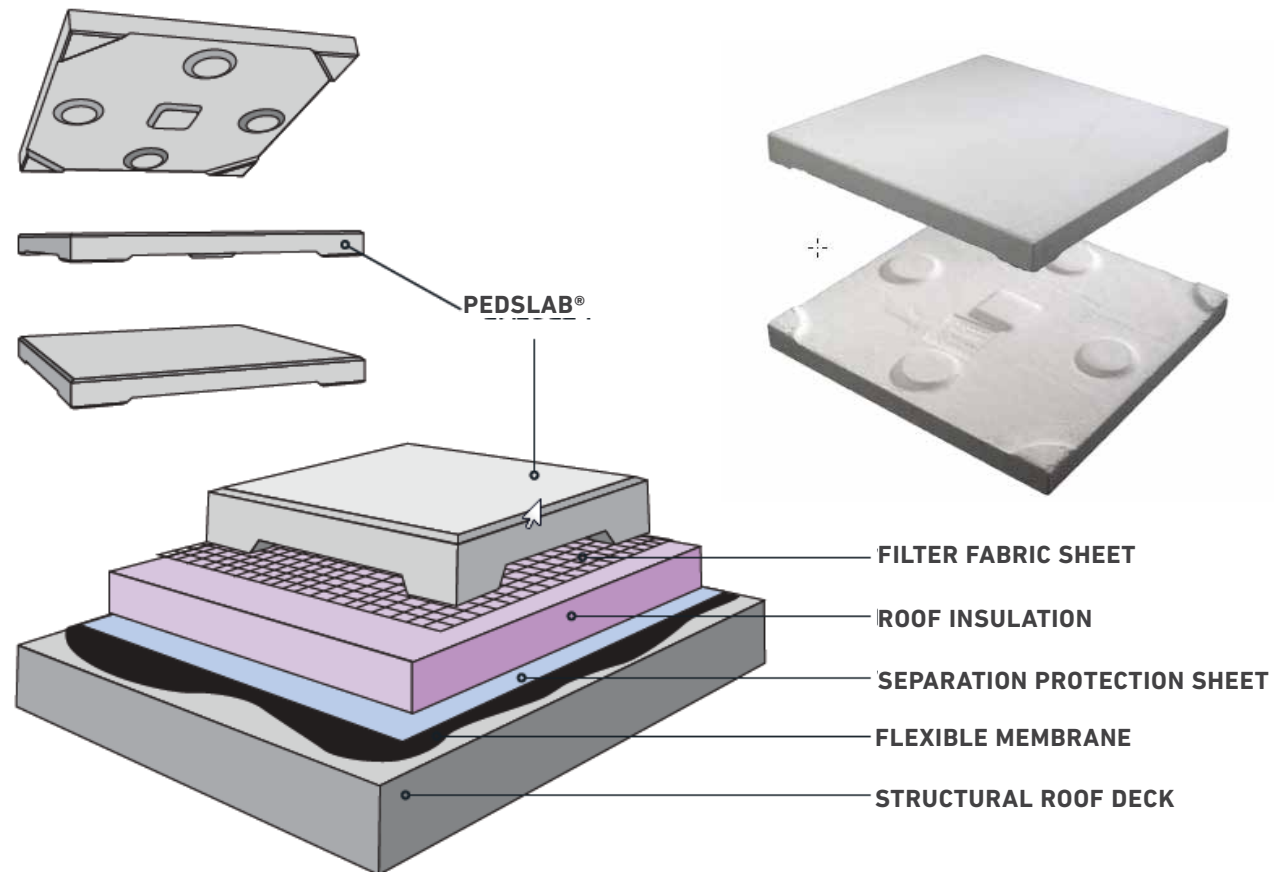

JEWELL PLAZA CONCRETE SLABS

- Contemporary smooth finish
- Ideal for pedestal set applications
- Provide a durable pedestrian surface
- Large size ideal for plazas and rooftop systems

DIMENSIONS:

23.5" x 23.5" x 2" nominal

WEIGHT:

96 lbs.

QTY/PALLET:

22 units

PALLET WEIGHT:

2,225 lbs.

WATER ABSORPTION:

5% per ASTM C140

POINT LOAD:

2,000 lbs. point load

FREEZE THAW:

1% loss of dry weight per ASTM C67



BALLAST PAVERS

The Ballast Rooftop Pavers are designed to prevent uplift from high winds. These high-density concrete pavers provide a consistent, evenly distributed weight from wind uplift and damage. Additionally, Ballast Pavers also protect the roof system from UV degradation, thermal shock and impact from hail or other falling objects.

DIMENSIONS:

8½" x 16" x 1½" nominal

WEIGHT:

13.75 per square foot

DIMENSIONAL TOLERANCE:

+/- 1/8" (length, width, height, convex, concave)

WATER ABSORPTION:

less than 5%

FREEZE THAW:

less than 1% loss in weight after 40 cycles

Do not use de-icing agents including but not limited to Ammonium Nitrate, Ammonium Sulfate, Sodium Chloride (Salt) and Calcium Chloride; these agents are destructive to concrete pavers.

During the course of the work and on completion, remove any cutting dust from the surface of the pavers by means of high pressure water or air. If left unattended, cut dust can and will discolor pavers. When cleaning with high pressure water, use caution to avoid damage to pavers.

Refer to the Ballast Paver Specification for more information, which is available for download on BelgardCommercial.com.

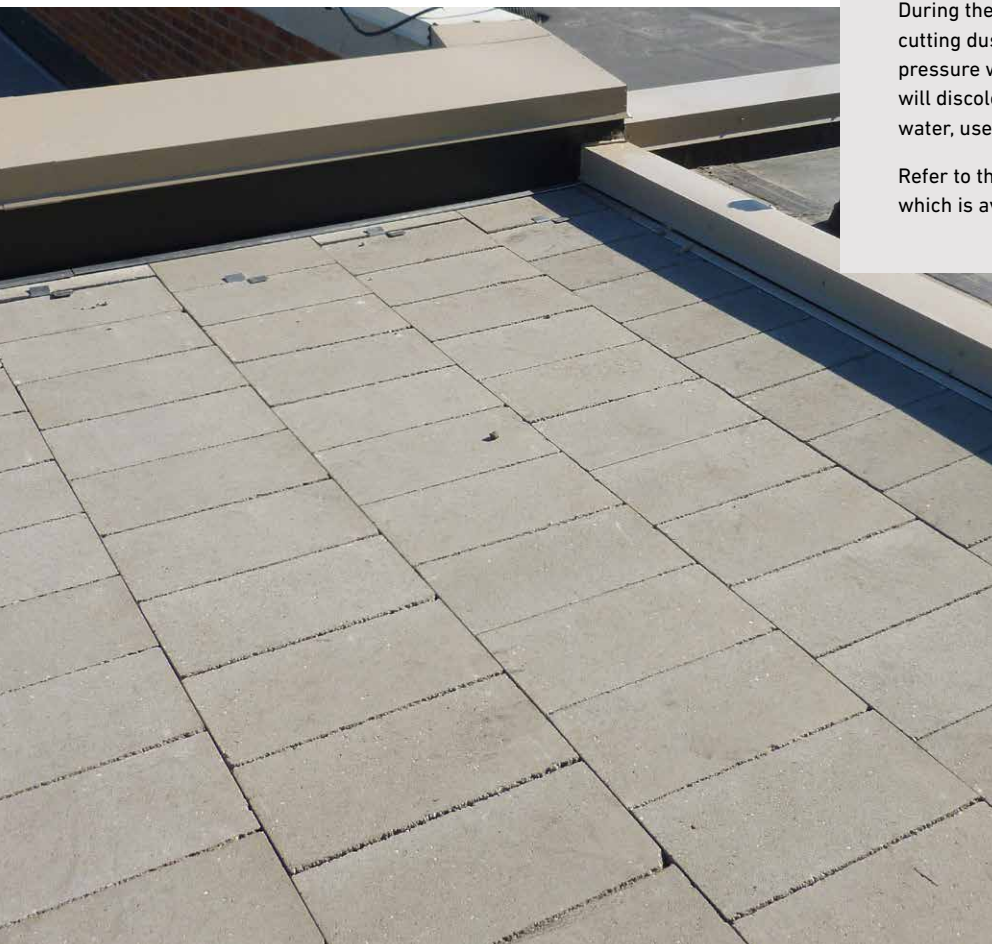

WOOD PLAZA PAVERS

Wood Plaza Pavers are an untreated, low maintenance, natural product made from either Cumaru, Bamboo, Itauba, Tigerwood or Ipe wood. All wood options are known for their high density, strength, durability and resistance to decay and insects. Depending on climatic conditions, Wood Plaza Pavers will develop an aged patina and faded coloring as they age. The ends of the wood tiles are sealed with wax at the factory to prevent splitting. Additional cuts made in the field should be sealed. Wax on ends can bleed into wood and be visible, but should become less noticeable over time.

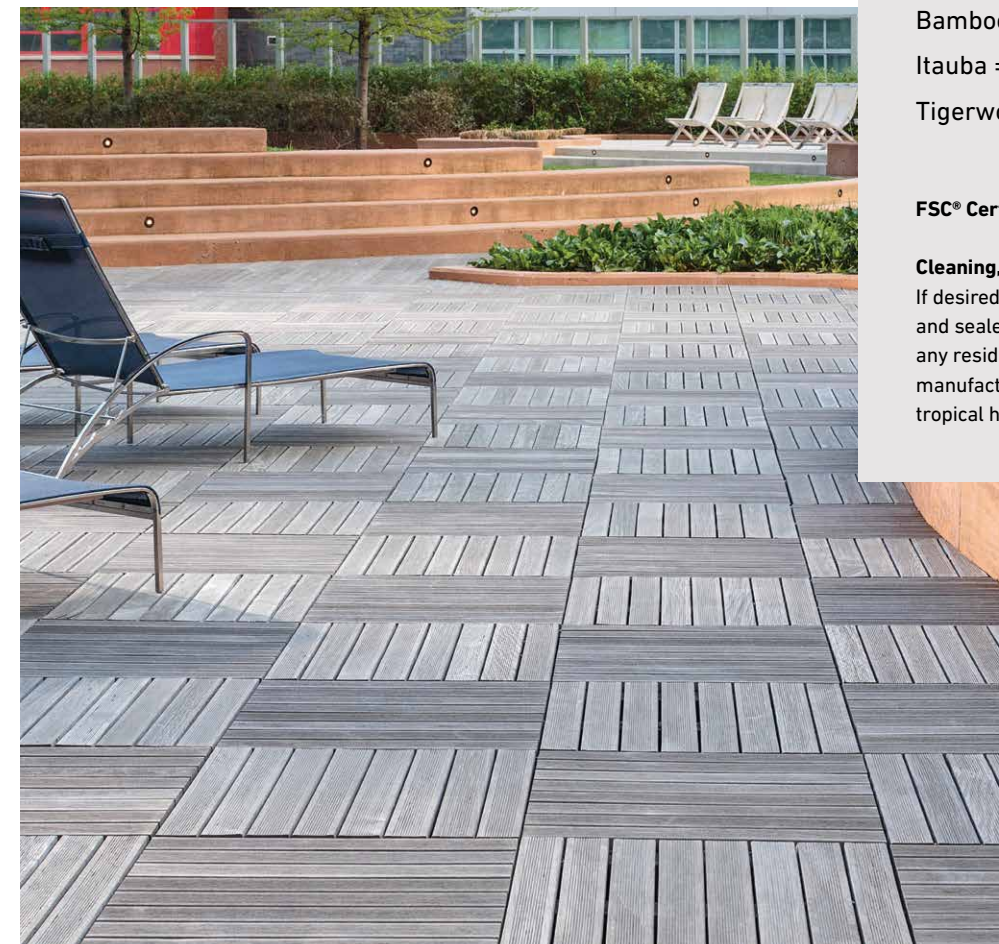

DIMENSIONS:

23⅞" x 23⅞" x 1.69" nominal

23⅞" x 47⅞" x 1.69" nominal

WEIGHT:

4-6 lbs per square foot based on species of wood

SURFACE:

Smooth

FIRE RATING:

Class A (ASTM E 108-07a Spread of Flame)

COLOR:

Brown (natural variations to be expected)

JANKA HARDNESS RATING:

Ipe = 3,680 lbf

Cumaru = 3,540 lbf

Bamboo = 3,850 lbf

Itauba = 2274 lbs

Tigerwood = 2170 lbs

FSC® Certified Available (FSC-C131838)

Cleaning, Sealing, Staining:

If desired, Wood Pavers can be periodically cleaned, stained and sealed. Before applying any finish, first clean and remove any residue or excess wax from the wood paver. The following manufacturers offer products specifically designed for use with tropical hardwoods: Cabots, Penofin, Messmers.

CUBES & CUBE TOPS

These popular powder-coated aluminum and Ipe wood cubes provide a great way to add accents to commercial plazas. Each powder-coated aluminum or Ipe wood cube can be used as a stand-alone accent, as a planter, or combined for a multidimensional look. Made of 100% natural wood, the Ipe cubes are eco-friendly and resistant to mold, fire, weather and pests. You can also add a cube top to create bench seating and storage. The choice is yours!

Powder-Coated Aluminum Cubes

COMMON DIMENSIONS:

24" L x 24" W x 20" H

24" L x 24" W x 36" H

48" L x 24" W x 20" H

48" L x 24" W x 36" H

MATERIAL:

Recycled raw material content (40% minimum)

Ipe Wood Cubes

COMMON DIMENSIONS:

24" L x 24" W x 16½" H

48" L x 24" W x 16½" H

MATERIAL:

Hardwood harvested sustainably from Brazilian Forests

All Cubes and Tops are made to order.

Custom sizes and colors are available. Contact your Westile representative for more information.

Cube Top



Aluminum



Ipe Wood



Colors & Finishes

Jewell *(Only available in Texas)*

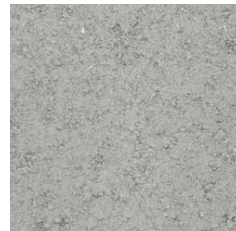

5501 | Natural



5502 | Red



5503 | Cinnamon



5504 | Charcoal



5505 | Coral



5506 | Ginger



5508 | Burgundy



5509 | Chamois



SRI White*

Shot Blast



Cinnamon



Limestone



Natural



SRI White*



Chamois



Charcoal



Ginger



Red

* SRI Color - Solar Reflective Index in Excess of 80

NOTICE: Colors subject to change without prior notice. Colors in this brochure may vary from current stock. Actual samples are available from Belgard Commercial. Slight variations in color may occur during manufacturing. Slight scuffing may occur during handling.

Diamond *(Only available in Eastern U.S.)*



Cinnamon

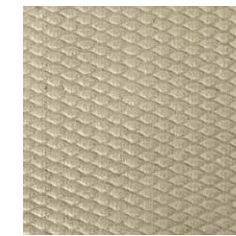

Limestone



Natural



SRI White*



Chamois

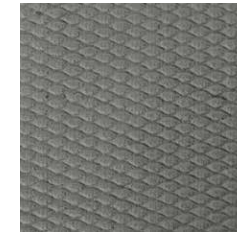

Charcoal

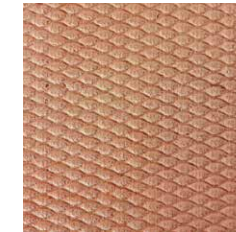

Ginger

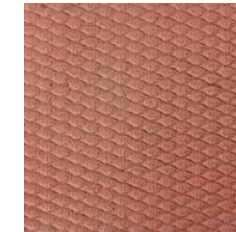

Red



Brooklyn

Matte



Cinnamon



Limestone



Natural



SRI White*



Chamois

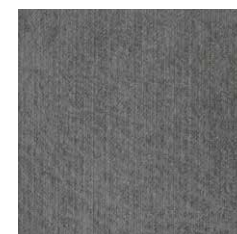

Charcoal



Ginger



Red

Wood Pavers

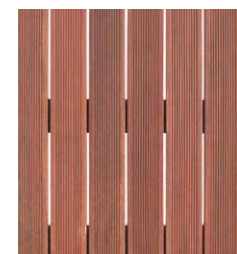

Massaranduba Ribbed



Smooth Cumaru



Smooth Ipe

Product Details

PLAZA ROOFTOP SLABS & PAVERS														
PRODUCT NAME	MATERIAL	PAVER THICKNESS (NOMINAL)	SIZE (NOMINAL)	APPLICATIONS					FINISHES				PIECES PER PALLET	SQ. FT. PER PALLET
				Pedestrian	Rooftops & Plazas	ADA	Roof Protection	Manual Installation	Standard/Smooth	Diamond	Matte	Shot Blast		
Classic Utility Slabs	Concrete	2"	24" x 24"	✓	✓	✓	✓	✓		✓	✓		25	100
Classic Plaza Slabs	Concrete	2"	24" x 24"	✓	✓	✓	✓	✓		✓	✓	✓	24	96
Classic Plaza Slabs	Concrete	2"	12" x 24"	✓	✓	✓	✓	✓		✓	✓	✓	48	96
Classic Plaza Slabs	Concrete	2"	24" x 36"	✓	✓	✓	✓	✓		✓	✓	✓	24	144
Western Plaza Slabs	Concrete	1 ³ / ₁₆ "	24" x 24"	✓	✓	✓	✓	✓			✓	✓	24	96
Jewell Plaza Slabs	Concrete	2"	24" x 24"	✓	✓	✓	✓	✓	✓				22	88
Ballast Rooftop Pavers	Concrete	1.6"	8.5" x 16"				✓	✓	✓				200	189
Ipe Wood Plaza Pavers	Wood	1.5"	24" x 24"	✓	✓	✓	✓	✓	✓				44	176
Ipe Wood Plaza Pavers	Wood	1.5"	24" x 48"	✓	✓	✓	✓	✓	✓				22	88
Cumaru Wood Plaza Pavers	Wood	1.5"	24" x 24"	✓	✓	✓	✓	✓	✓				44	176
Cumaru Wood Plaza Pavers	Wood	1.5"	24" x 48"	✓	✓	✓	✓	✓	✓				22	88
Eco-Ipe Wood Plaza Pavers	Wood	1.5"	24" x 48"	✓	✓	✓	✓	✓	✓				22	88

NOTICE: Check with your Belgard Commercial Representative for product availability.

Product Details

MODULAR BENCHES & CUBES

PRODUCT NAME	COMMON SIZES (CUSTOM SIZES AVAILABLE)	COLORS (CUSTOM COLORS AVAILABLE)	MINIMUM QTY
Powder-Coated Aluminum Cube	24"L x 24"W x 20"H	Red, Black, White, Charcoal, Silver	1
Powder-Coated Aluminum Cube	24"L x 24"W x 36"H	Red, Black, White, Charcoal, Silver	1
Powder-Coated Aluminum Cube	48"L x 24"W x 20"H	Red, Black, White, Charcoal, Silver	1
Powder-Coated Aluminum Cube	48"L x 24"W x 36"H	Red, Black, White, Charcoal, Silver	1
Ipe Cube	24"L x 24"W x 16.5"H	Brown (Natural variations occur)	1
Ipe Cube	48"L x 24"W x 16.5"H	Brown (Natural variations occur)	1
Ipe Top	24" x 24"	Brown (Natural variations occur)	1
Ipe Top	48" x 24"	Brown (Natural variations occur)	1

NOTICE: All cubes and tops are made to order.



PEDESTALS & ACCESSORIES

PRODUCT NAME	PRODUCT DESCRIPTION	PIECES PER CARTON
STAR-T	3/8" - 9/16" (10-15mm)	50
STAR-B	3/16" Extension (5mm)	50
SE0-P	1.125" - 1.5" (28-38mm)	40
SE1-P	1.5" - 2" (37.5-50mm)	30
SE2-P	2" - 3" (50-75mm)	25
SE3-P	3" - 4.75" (75-120mm)	25
SE4-P	4.75" - 6.75" (120-170mm)	25
SE5-P	6.75" - 8.75" (170-215mm)	25
NM-1	1" - 1.57" (25-40mm)	40
NM-2	1.57" - 2.75" (40-70mm)	30
NM-3	2.36" - 3.93" (60-100mm)	25
NM-4	3.54" - 6.30" (90-160mm)	15
NM-5	5.90" - 10.63" (150-270mm)	12
NM-EXT	5.7" Extension (145mm)	30
EH-12	1/2" Fixed (12mm)	250
EH-15	5/8" Fixed (16mm)	200
EH-20	3/4" Fixed (20mm)	150
RUB-14	1/4" Fixed RUBBER	150
RUB-38	3/8" Fixed RUBBER	150
RUB-PINS	1/4" Fixed w/ 4 Pins	100
PR1	1.2" - 2.55" Adjustable Pedestal	1 per box
PR2	6.1" Adjustable Pedestal	1 per box
PR3	16" Adjustable Pedestal	1 per box

NOTICE: Check with your Belgard Commercial Representative for product availability.



THE "KEY" TO YOUR SUCCESS

Our unique "Adjustment Key" allows you to level and adjust our Pedestal Supports WITHOUT removing the paver. This unique feature saves labor costs and reduces possible injuries from heavy pavers



BLOCK SYSTEM

Block system indicates to installer when unit has safely reached its maximum height adjustment. A cut out is also part of this system that allows the installer to push in a safety tab, releasing components if necessary.

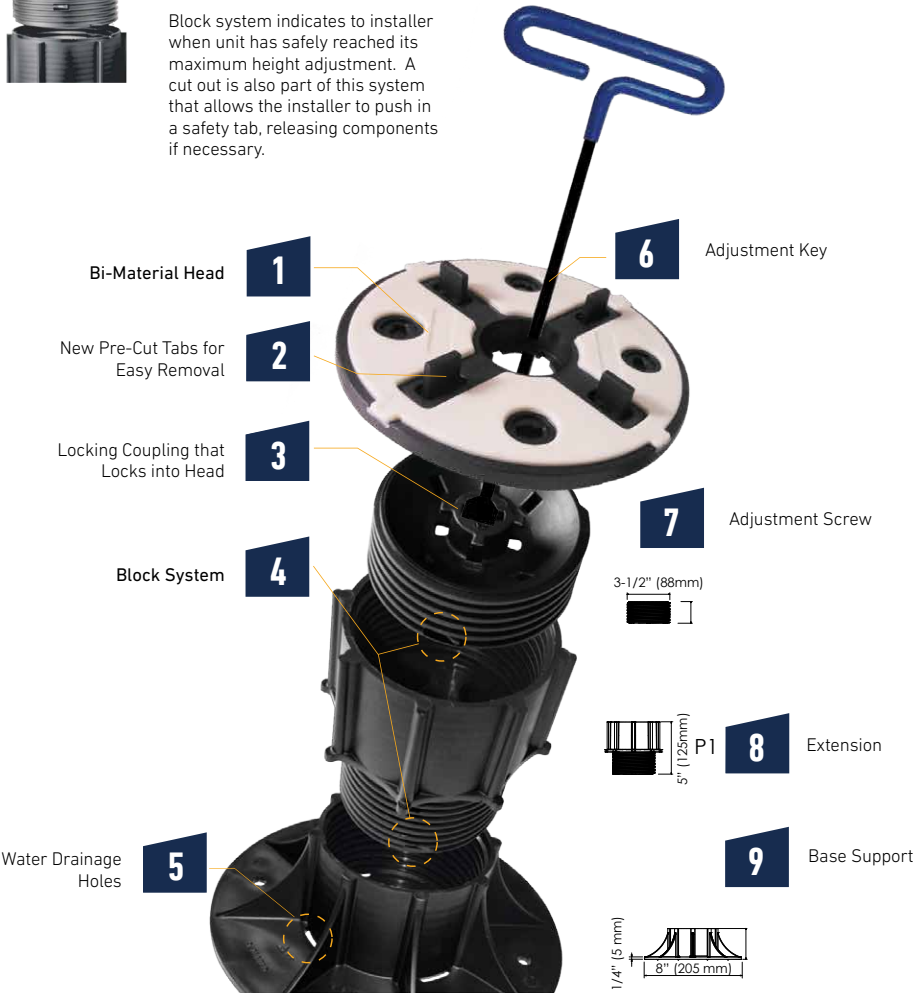

FEATURES	SUPPORTS
#1 Bi-Material Head	New Self-Leveling Head with Bi-Material PP & Rubber Anti-Noise & Anti-Slip
#2 Pre-Cut Tabs	Easy removal of Tabs When Needed
#3 Locking Coupling	Coupling Locks Into Head
#4 Block System	New Self-Leveling Head with Bi-Material PP & Rubber Anti-Noise & Anti-Slip
#5 Water Drainage Holes	No Ponding Water
#6 Adjustment Key	Levels Support without Removing Paver
#7 Screw	V0 3/4" (19mm) / V1 7/8" (22mm) / V2 1-1/4" (35mm) / V3 2-1/4" (60mm) / V4 4" (105mm) / V5 6" (155mm)
#8 Extension	Extension for Higher Requirements
#9 Base	B0 5/8" (16mm) / B1 7/8" (25mm) / B2 1-5/8" (40mm) / B3 2-1/2" (65mm)



LOCKING COUPLING

Allows head to be locked into the threaded screw.



BASE PRE-CUT LINES

Base bottom with pre-cut lines for easy and precise cuts when needed for corner placement situations.

ADJUSTABLE PEDESTALS

SE & NM SERIES

PAVER INSTALLATION SYSTEM FOR UNLEVEL SURFACES OR FOR ALLOWING ACCESS TO UTILITIES

FEATURES & BENEFITS

- Bi-material head for increased stability and sound dampening
- Ability to raise and lower pedestals with pavers in place using adjustment key
- High load capacity
- Efficient installation

SE SUPPORT	
Self-Leveling Head	✓
Fixed	✓ With the Eterno Lock fixed locking piece only
Adjustable	✓
Extension Element	✓
Adjustment Key	✓
Locking IPE Pins	✓
Recyclable (LEED)	✓
Loading Capacity	2205 LBS. (1000 KG)
Height Range	1.125" - 21.75" (28 MM - 550 MM)

NM SUPPORT	
Self-Leveling Head	NA
Fixed	✓
Adjustable	✓
Extension Element	✓
Adjustment Key	✓
Locking IPE Pins	✓
Recyclable (LEED)	✓
Loading Capacity	3000 LBS. (1500 KG)
Height Range	1" - 10.63" (25 MM - 270 MM) 39" With Extensions

Check with your local Belgard Representative for product availability.



FIXED HEIGHT PEDESTAL ACCESSORIES

FEATURES & BENEFITS

- Ideal for low height applications
- Stackable for more precise fit
- Facilitates fast water drainage to resist mold
- Absorbs expansion and structural movement

STAR T & EH SERIES

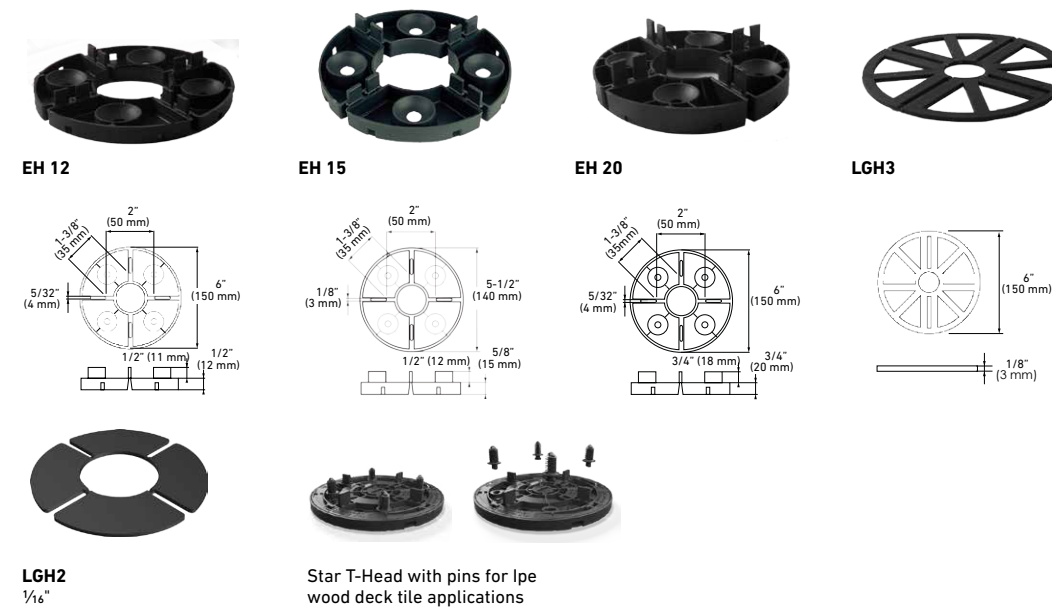



PEDESTAL PRIME

ADJUSTABLE PEDESTAL SYSTEMS

FULLY INTEGRATED SYSTEM FOR ROOFTOP PAVER INSTALLATIONS

FEATURES & BENEFITS

- Compatible with concrete, wood and porcelain pavers to improve rooftop performance or convert to usable space
- Ideal for uneven surfaces or slopes from 0 to 5%
- Integrated safety indicators to prevent over extension
- Three sizes for adjustable height from 1.18" to 16.53"
- Allows easy access to rooftop utilities
- Higher heights can be achieved with extension couplers

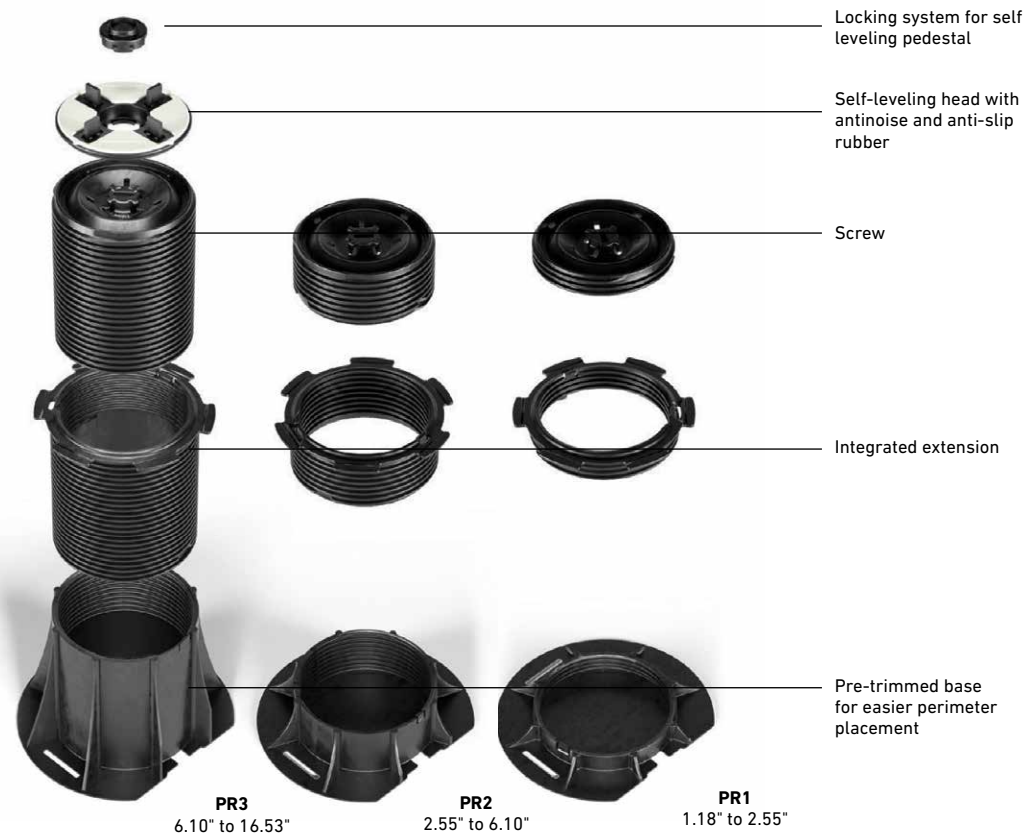

Check with your local Belgard Representative for product availability.



SCREWJACK ACCESSORIES



MODEL LD4
Provides 0"-1/4"
slope compensation



MODEL B11
Shim adds 1/16" for fine
tune adjustment



MODEL PS1
Shim adds 1/8" for fine
tune adjustment



MODEL HD25
Fixed 1/4" height with
3/16" spacer tab



MODEL HD50
Fixed 1/2" height with
3/16" spacer tab



MODEL HD75
Fixed 3/4" height with
3/16" spacer tab



VT316
Ultra low height 3/16"
tab - 4% diameter

Check with your local Belgard Representative for product availability.

SCREWJACK

ADJUSTABLE PEDESTALS

PREASSEMBLED PEDESTALS FOR CONSTRUCTION OF PLAZA DECKS OVER SLOPING OR DIFFICULT SURFACES

FEATURES & BENEFITS

- Improves commercial rooftop performance or convert into usable space
- Adjustable elevation from 1/8" to 36"
- Easy screw-to-adjust functionality
- Speeds installation of wood and concrete pavers and slabs
- Allows future access to utilities and surface below
- Supports up to 1,000 lbs.
- Impervious to water, mold and freeze-thaw
- Contains 20% post-industrial recycled material

SHAPES & SIZES

MODEL B1



Adjusts from 1 1/4"-2"
with 3/16" spacer tab

MODEL B2



Adjusts from 2"-3"
with 3/16" spacer tab

MODEL B3



Adjusts from 3"-4 3/4"
with 3/16" spacer tab

MODEL B4



Adjusts from 4 3/4"-7 3/4"
with 3/16" spacer tab

MODEL C4



Coupler adds 2 1/2"-4"
in height to B3 & B4

Check with your local Belgard Representative for product availability.

Installation Instructions

LEVEL SYSTEM

The Level System is used for a dead level paver surface. This system allows for installation of a level paver surface over various sloping substrates. This system is for conventional or IRMA Roof Assembly and for pedestrian use only.

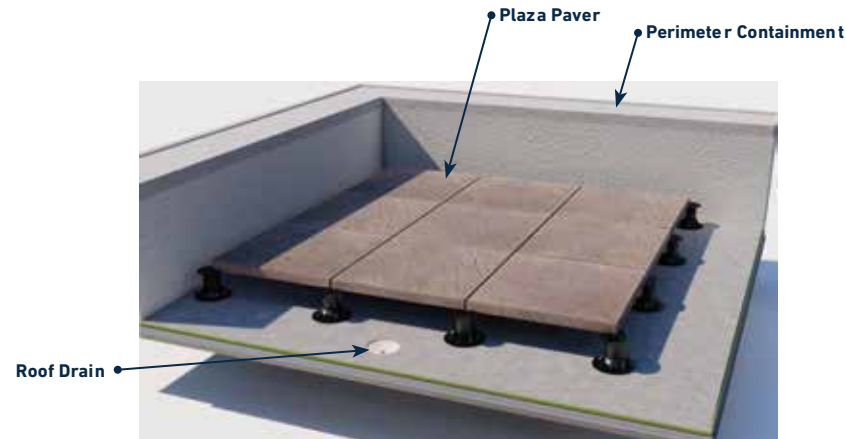

SLOPED SYSTEM

The Sloped System can be used when a dead level paver surface is not necessary. Pedestals are loose-laid and not attached to the roof assembly.

PEDESTAL SELECTION / ELEVATION

Installation requirements vary for each individual project site. Paver size, pattern, grid layout, starting point and finished deck surface elevation should be shown on shop drawings which have been approved by the designer, installing contractor and owner. Measurements from the construction site should be used for final pedestal selection and purchasing. The Finish Deck Surface Elevation is determined at the door threshold. The shortest pedestals are usually at the door threshold and the tallest are at the roof drains. To obtain pedestal height, subtract paver thickness from the Finish Deck Surface Elevation. If insulation is used, the insulation must have a minimum 40 psi compressive strength. Otherwise, a protection/recovery board is required.

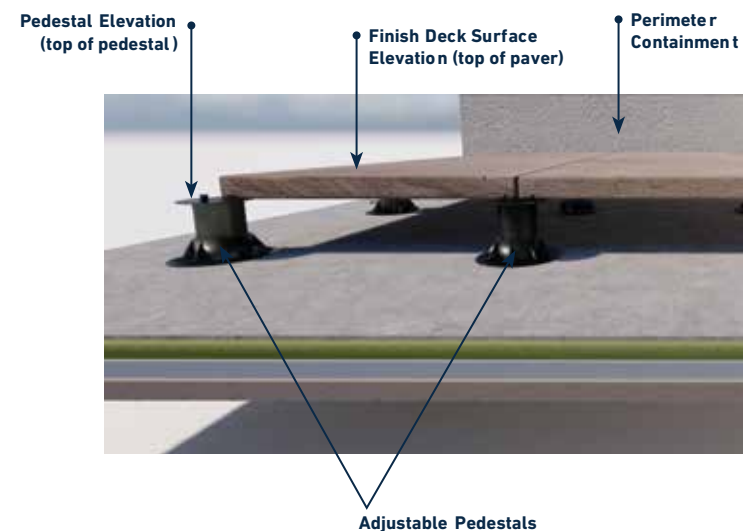
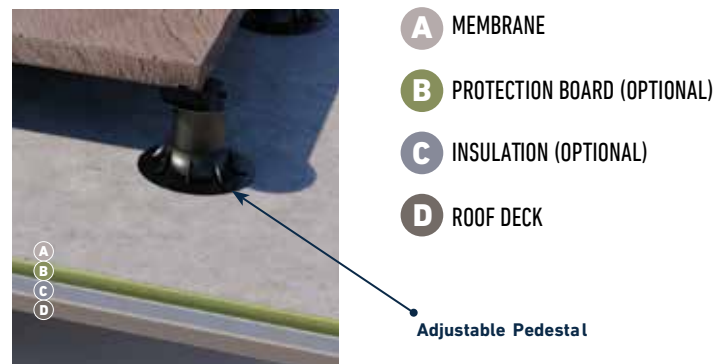

Rooftop Paver Layout Service

WE CAN HELP WITH YOUR PROJECT

During the bid phase of a project, Belgard Commercial® can provide a rough component count based on square footage. This will include paver counts and pedestal counts. Once the project is awarded, a detailed layout (example 1) can be created showing more precise pedestal counts, heights and locations. This detailed layout takes approximately 5-7 business days to complete.

To create the detailed layout, the following information must be provided:

1. Paver type and size to be installed (i.e. Concrete, Wood or Porcelain; i.e. 24"x24")
2. Deck plan showing area (example 2)
3. Section detail (example 3)
4. Slope and drain locations (example 4)
5. Starting / threshold height (example 5)

EXAMPLE 1

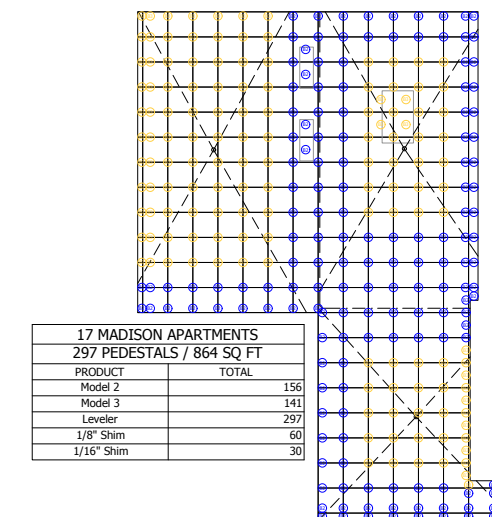

EXAMPLE 2

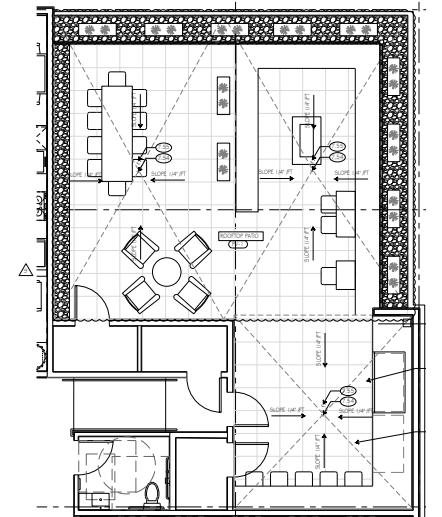

EXAMPLE 3

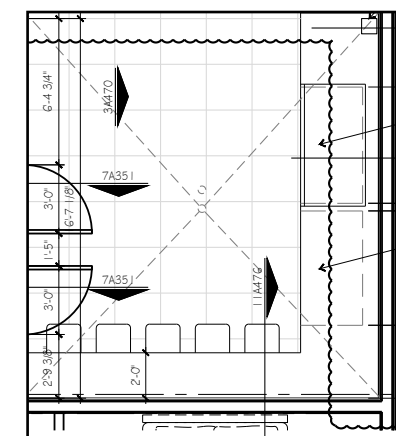

EXAMPLE 4

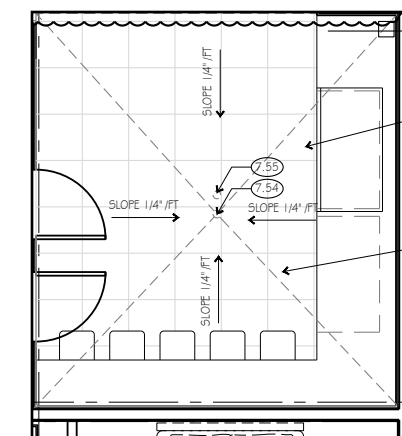

EXAMPLE 5

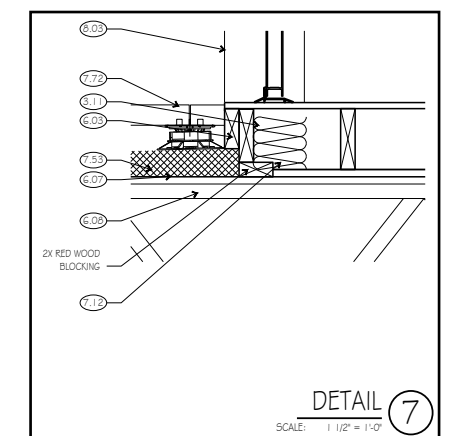





REFERENCE INFORMATION

PROFESSIONAL SUPPORT



ENVIRONMENTAL SOLUTIONS

Belgard consultants can work with your team to develop the best PICP system design or retaining wall configuration to control runoff volume and discharge rates, improve the quality of local groundwater, reduce or prevent downstream impacts, and minimize the land consumed for stormwater management.



SITE PLANNING

The experts at Belgard can help you optimize your site in a number of ways—whether you're looking for creative ways to define public spaces, manage or harvest stormwater, or increase the useable space for development.



ENGINEERING SERVICES

Our team of design consultants can help address both aesthetic and engineering design concerns, material quantity estimates and permit ready plans.



CAD FILES

For your convenience, Belgard offers a constantly expanding library of easy-to-download CAD files of our products and patterns.



CONTINUING EDUCATION

Belgard offers a variety of ongoing educational programs for our industry partners, including Lunch & Learns, online CEU courses, and our Belgard University training program.



Oldcastle APG
A CRH COMPANY

400 Perimeter Center Terrace, Suite 1000
Atlanta, GA 30346
Ph: 844-495-8210

belgardcommercial.com